

Model No. BO001CG BP RANDOM ORBIT SANDER

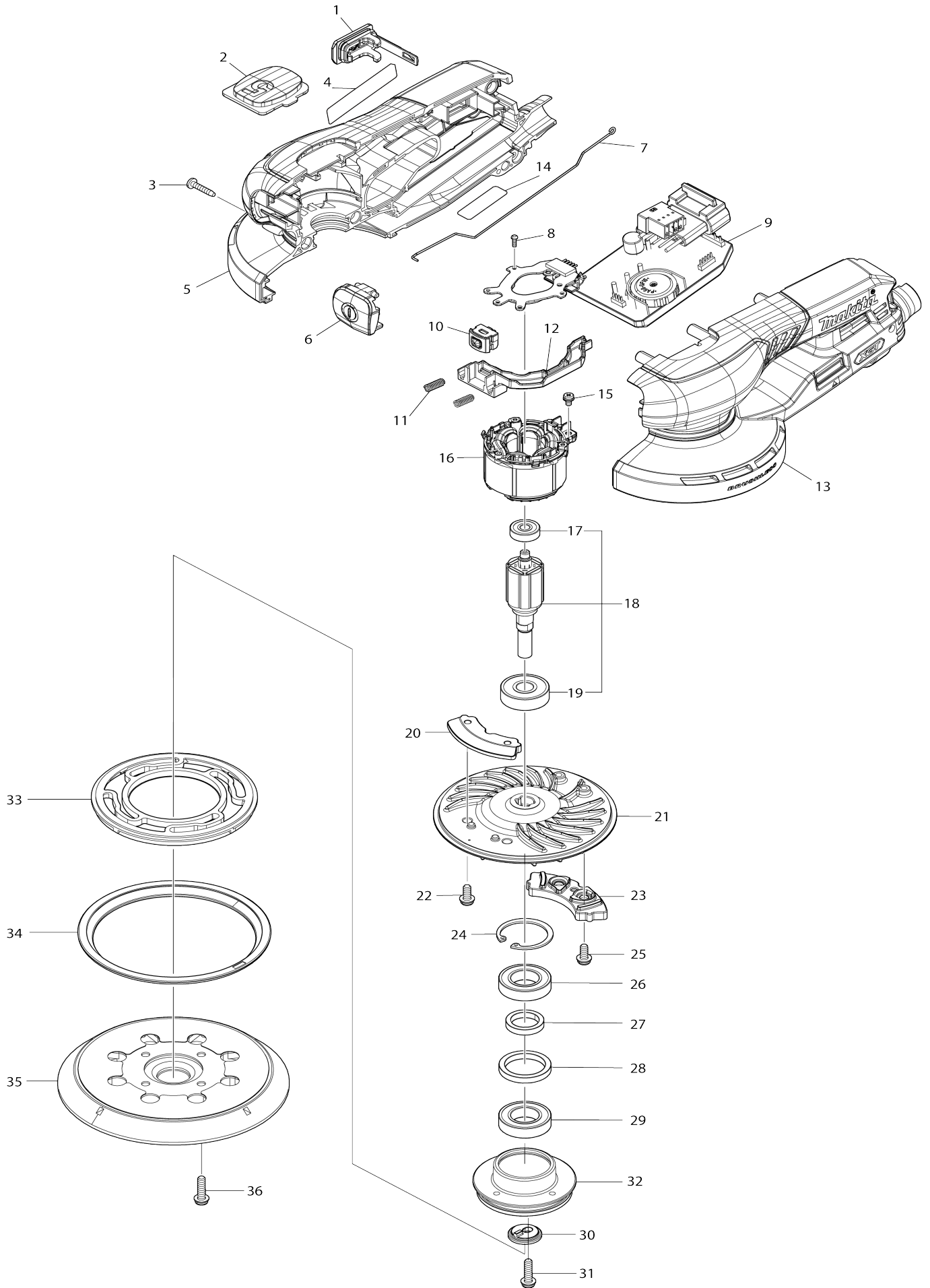

Model No.BO001CG BP RANDOM ORBIT SANDER

Č. pol ožky	Č. dielu	Popis	Zame niteľn osť	Množ.	Nový/ starý	Poznámka 1	Poznámka 2
001	140F99-0	Uzáver kompletný		1			
C10	213A05-9	O-krúžok 16		1			
002	413Y41-1	INDICATION PLATE		1			
003	266429-2	Samorezná skrutka s valcovou hl avou 3X16		7			
004	8145P4-6	BO001CG NAME PLATE		1			
005	1830M5-7	HOUSING SET		1			
C10	252126-6	Šesthranná poistná matica M4-7		2			
D10		INC. 13					
006	413Y40-3	SWITCH BUTTON		1			
007	327D45-0	EARTH WIRE		1			
008	266490-9	Samozávrtná skrutka s plochou hlavou 2X6		3			
009	620P00-6	CONTROLLER		1			
010	632L84-8	Jednotka spínača		1			
011	233436-0	Prítlačná pružina 3		2			
012	413Y39-8	SWITCH HOLDER		1			
013	1830M5-7	HOUSING SET		1			
C10	252126-6	Šesthranná poistná matica M4-7		2			
D10		INC. 5					
014	8145P5-4	BO001CG SERIAL NO. LABEL		1			
015	652069-6	Skrutka s plochou hlavou M3X6		3			
016	629C61-5	STATOR		1			
017	210035-5	Guľôčkové ložisko 625DDW		1			
018	519843-4	ROTOR ASS'Y		1			
D10		INC. 17,19					
019	211092-6	Guľôčkové ložisko 629DDW		1			
020	313534-7	UPPER BALANCE WEIGHT		1			
021	240250-7	FAN 98		1			
022	911111-5	Skrutka s polguľovou hlavou M4 X10 W		2			
023	313535-5	LOWER BALANCE WEIGHT		1			
024	962106-1	Vnútrotny poistny krúžok (Seeger ova podložka) R-28		1			
025	911111-5	Skrutka s polguľovou hlavou M4 X10 W		2			
026	211244-9	Guľôčkové ložisko 6902LLU		1			
027	257868-7	Krúžok 15		1			
028	257A34-2	RING 22		1			
029	211244-9	Guľôčkové ložisko 6902LLU		1			
030	313518-5	RETAINER		1			
031	911128-8	Skrutka s polguľovou hlavou M4 X16 WR		1			
032	312F10-4	BEARING BOX		1			
033	424131-5	Krúžok brzdy		1			
034	422B47-0	RUBBER GUARD		1			
035	1914J2-2	PAD125 SET		1			
036	911128-8	Skrutka s polguľovou hlavou M4 X16 WR		4			
A01	122G32-0	DUST BAG ASSY		1			

A02	154553-2	ARM BAND COMPLETE		1			
A03	413Y47-9	FRONT CUFF 22		1			
A04	D-78667	NET SANDING DISC 125MM A120		1			
A05	D-78704	PAD SAVER DISC 125MM		1			
A06	1914H3-6	BATTEY ADAPTER SET		1			
D10		COMPO-PARTS					
F01	1914H3-6	BATTEY ADAPTER SET		1			
F02	1914H5-2	BATTEY ADAPTER SET		1			

Pri objednávke zadajte číslo dielu.

Dátum tlače 22. 07. 2024